

International Costumer

Volume XIV, Issue 3

May-June 2015



Buccaneers, Belles, and Bootleggers!

President's Message

By Philip Gust

Although summer hasn't officially arrived, things are really heating up for many ICG members who are getting ready for costuming events in the next several months. Here are a few highlights.

First is Costume-Con 33, which takes place in Charleston, South Carolina from May 15-18. In addition to the many classes and hands-on workshops, there are several masquerades and a number of opportunities for costumers to strut their stuff. Kathe and I are busy preparing an entry for the Historical masquerade that we may just get done with a bit of luck and a good tail wind.

Next comes Anime North, which takes place in Toronto, Ontario in Canada from May 22-24. This is one of the largest anime and cosplay conventions anywhere. The level of energy and enthusiasm, and the quality of costuming are both at their peak for this event. I love the aesthetic of anime costumes, and the spectacular way that anime costumers present them on stage. I look forward to trying my hand at it some time.



Kathe as Princess Isabella of Portugal and Philip as Philip the Good, Duke of Burgundy at a costumed event at Castello di Ambrosa. Photo by Jack Rabbit Digital.

Then there's San Diego Comic-Con from July 9th to July 12. This mind-blowing event has more superheroes per square meter than the comics where they originated. Even if you just walk around the exhibit halls and admire the amazing costumes, it's worth the price of admission. The masquerade is the highlight of the show, and the audience is treated to some of the best costuming anywhere. From experience, I can also say that entering the masquerade is an experience you'll never forget.

Finally there's Sasquan, the 73rd World Science Fiction Convention, which takes place in Spokane, Washington from August 19th-23. This convention has a literary focus, but costumers show up in fantastic sci-fi and fantasy themed costumes. The masquerade gives many of them a chance to show off their work to an appreciative audience. This year, Silicon Web Costumers' Guild president Kevin Roche will be the Master of Ceremonies. An article in this issue by masquerade director Sharon Sbarsky provides more information.

For a listing of the many events throughout the year, see the Upcoming Conventions page on the ICG website:

<http://www.costume.org/conventions.html>.

The ICG annual board and member meetings will take place at Costume-Con 33 on Friday, May 15th. The board meeting is from 9 - 10.30am and the member meeting is from 10:45 - 11:45. You can read about the meetings in a posting on the ICG-D Yahoo group:

<https://groups.yahoo.com/neo/groups/icg-d/conversations/messages/49493>.

I will post a final agenda in the first week of May. If you will not be attending, let me urge you to complete a proxy form and send it with someone who will be. You can

access a proxy form on the ICG website:

<http://www.costume.org/documents/proxy.html>.

Finally, I'm pleased to make four announcements.

1. The Marty Gear Costuming Arts and Sciences Fund board just announced that photographer Richard Man was awarded a grant to support his "Transformations: Cosplay" project. Fund chair Byron Connell describes the project and the grant more fully in this issue. Congratulations, Richard!

2. The board has approved a new ICG chapter: the Time Travelers Costumers Guild, located in the greater Portland Oregon metro area. I and the other ICG officers will be working closely with the founding members to help bring them on board and help them get started. They plan to tell us more about themselves in an upcoming issue.

3. The board has also approved ICG's second Special Interest Group (SIG): Props and Costuming FX. This SIG provides a focus for those who are interested in learning and sharing information about prop making and

creating costuming special effects such as lighting, sound, mechanicals, and other effects that enhance costumes. More information about the new SIG and how to join will be available shortly. As someone who is handier with a soldering gun than a serger, I'm excited about this new SIG!

4. The ICG is now making proof of membership available to members. Those who receive the online edition of the newsletter will find it in the email notification for each issue. Those who receive the print edition will find it on the address label. Your proof of membership includes your name, address, the expiration date, and your primary chapter. In addition to helping you remember when it's time to renew, you can use your proof of membership for discounts and other benefits from merchants who offer them to members of non-profits like the ICG. A new page on the ICG website provides information on available discounts. If you discover a discount, please share it by sending information to the webmaster (webmaster@costume.org, subject line "discount") to add to this page.

Editor's note: A copy of the proxy form for the annual ICG board and member meeting can be found at the end of the newsletter.

New Marty Gear Grant for Richard Man's Transformations Cosplay Project

By Byron Connell

On April 5, the Marty Gear Costuming Arts and Sciences Fund approved ICG member Richard Man's application for a grant to support his Transformations Cosplay Project. In this project, Mr. Man will examine "how costumers/cosplayers transform themselves from their 'mundane' daily appearance to temporarily 'become' the characters they portray." His application explained that he takes "traditional-style portraits . . . with an eye toward gallery exhibition and large-format book publication, using . . . 4x5 large-format film cameras. The main focus is on the characters themselves. The photos are accompanied by textual excerpts of audio interviews I do with the costumers to give further insight into the people behind the costumes; for example: what sparked their interest in costuming, the reasons behind particular choices of costumes, challenges and details they enjoy about costume creation. . ." and that "The goal is to photograph cosplayers/costumers from as many regions as possible. . . ."

Mr. Man sees the purpose of Transformations Cosplay as to "raise the awareness of and respect for costumers and our costuming arts and techniques; not just

within the SF&F communities, but also in the general public and the greater art community as a whole. Additionally, this provides opportunities to promote awareness of the existence and history of costumer organizations such as the ICG and its various chapters.

"The juxtaposition of the costumers both in costume and also in their 'regular lives' (in regular clothes, often with some representation of their daily jobs) is intended to show costumers as 'regular' people of all ages and from all walks of life who also happen to engage in this amazingly fun and highly creative hobby; costumers/cosplayers are not a 'bunch of crazy fringe weirdos' or 'just skimpy soft-core exhibitionists' that media portrayals often make them out to be."

The ICG's grant, for \$750, will provide additional general support for the Transformations Cosplay project. Mr. Man intends to present the project at Costume-Con and other science fiction, anime, and genre conventions. He seeks to publish the results in book form and to display the photos on websites, at convention art shows, and in galleries. He will submit web sized images for permanent retention in the Pat and Peggy Kennedy Memorial Archives.

Sasquan Masquerade

By Sharon Sbarsky

This summer, the 73rd World Science Fiction Convention will be held in Spokane, Washington, August 19-23, 2015.

The Worldcon Masquerade is a judged costuming competition and stage show. Entrants are divided into divisions based on the costuming skill levels of the participants, and judged by a panel, including some of our Guests of Honor and experienced costumers.

Our Masquerade will be held on Friday, August 21st, 2015. This is a very popular show, but there will be plenty of seating in the INB Performing Arts Center, so bring all your friends! The Theater doors will open at 7:30 pm and the show will start at 8 pm sharp.

Kevin Roche will be the Master of Ceremonies for the evening. We will be using the International Costumers' Guild (ICG) Fairness Guidelines Division System for entries. If you are considering entering please go to the Sasquan website at <http://sasquan.org/masquerade/rules/> to read more details. You can pre-register online to be sure to reserve a spot. Although it is advisable to premiere your costume at the Masquerade itself, this is not mandatory. If we find you in a fabulous costume in the hallways of the Convention,

we will recruit you into the Masquerade! If you are in doubt about entering, email us at masquerade@sasquan.org before arriving; or, please come by the Masquerade Registration table in costume, with a photo of you in your costume, or just talk to us about your costume, and we'll be happy to help you decide whether or not to enter. Masquerade Halftime will feature a performance by Guest of Honor Tom Smith.

And don't forget – one of the best ways to participate in the production of the Masquerade is to volunteer! We can't do it without you – and we'll need help for all aspects of the Masquerade. Want to see everything up close and personal? We can use your help in the Green Room. Want to be in the middle of the action? Become part of the stage crew for the evening, wearing black, being by the stage and insuring the safety of our Entrants. Want to document the costumes in photos? We'll have a fan photo area. Want to do more? Write to us at masquerade@sasquan.org, and we'll chat.

We're looking forward to a great Masquerade, with a special category based on Guest of Honor David Gerrold's books and stories. So join us — we'll have a blast!

Buccaneers Belles & Bootleggers

Costume-Con 33

By Sandy Swank and Dora Buck

Costume-Con is an annual gathering of mostly hobbyists from all over the world who enjoy sewing and creating costume of all kinds. This convention was started in California in 1983 by our founder Karen Dick. After that Costume-Con traveled to many other cities across the world, including Baltimore, MD; Albany, NY; Seattle, WA; and Denver, CO; also to Calgary and Toronto in Canada and as far away as Melbourne, Australia.

This 4 day conference hosts many different panels and workshops where one can learn new techniques ranging from basic to advanced sewing, to creating fashions that include adding LED lighting, mechanical moving parts, as well as makeup and hair fashions.

Our small (newly forming) group of costumers here in the Low Country is called "The Pirates of the Carolinas Costumer Guild" and with the help of the Greater Delaware Valley Costumer's Guild are pleased to have been chosen to be this

year's convention hosts. This year's theme is "Buccaneers, Belles and Bootleggers".

Our group wanted to incorporate the history of the City of Charleston together with common themes of interest such as Pirates, and Charleston being rich in its history of notable pirates. Civil War Reenactors and history buffs alike will pair well with the second theme being Belles; i.e. as any "Gone With The Wind" enthusiast knows both Ellen O'Hara (Scarlett's Mother) and the notorious Rhett Butler were from Charleston. Charleston is home to the famous civil war submarine the "H. L. Hunley", as well as being the site of the first shot of the American Civil War at Fort Sumter. Just taking a stroll on the Battery you can imagine ladies in hoop skirts and gentlemen in fine white linen suits. Last but not least, the fashions of popular TV shows and movies from Boardwalk Empire to Downton Abbey and the Great Gatsby, sets the stage for the Bootleggers part of the theme. Speakeasies and Rum Runners were once a part of the dark history of the City of Charleston.

Events featured during the weekend include several competitions - the Science Fiction and Fantasy Masquerade, Historical Masquerade, Single Pattern Show, Future Fashion Show, Quilt and Wearable Art Show and Doll Competition that include costumes in miniature size.

This year, one of the featured events will take place mid-morning on Sunday when we will host our "Southern Cotillion". This is a special competition entitled "Miss Ellen's Portiere's" (What will you do when it's curtains).

When you are not in a panel or workshop, please feel free to browse through the display of costumes from past Costume-Con and World-con Masquerade entries.

This year the official opening of the convention begins with our Friday Night Social, theme *Welcome to the Jazz Age*. Take a step back in time as you enter our

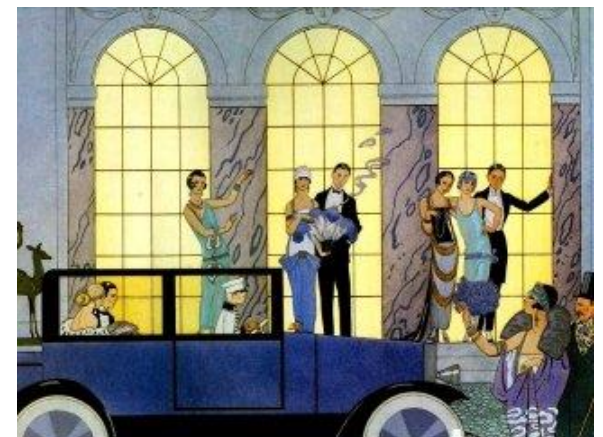

speakeasy and find yourself in the middle of a grand 1920's style party where you could meet anyone from *Thoroughly Modern Millie* to Blackbeard the Pirate, Dr. Who, or Sailor Moon.

Janet Wilson Anderson, Master Costumer, CEO of Alter Years, costume advisor for the



Janet Wilson Anderson

Showtime series *The Tudors*, will be our Guest of Honor. She has been involved in costuming for a long time and hosted Costume-Con 8 with her late husband, Gary Anderson.

Day and

Evening memberships and student rates are available at the door. Students must show a valid ID from a College or University. Please see our website www.cc33charleston.org for any other information and memberships through PayPal.

Anything is possible in this costume fantasy world.

Charleston City Tours Scheduled for Friday Morning & Midday Monday

Charleston, South Carolina, offers many attractions that are guaranteed crowd pleasers. Everything from the South Carolina Aquarium and Fort Sumter to carriage rides through the historic district. Pick up your parasols, don your hoop skirts, and have your photo taken on the Battery. Military aficionados can find interesting exhibits at the Museum of the Confederacy in the head house of the open market. Or visit the U.S.S. Yorktown at Patriots Point, containing the U.S. Medal of Honor Museum. The on-going excavation and restoration of the H. L. Hunley is taking place a short distance away in North Charleston. Ft. Moultrie on nearby Sullivan's Island is where Mr. E.A. Poe served his military duty, and was inspired to write *The Gold Bug* for those of a Goth persuasion. There is also the Charleston Museum, and several historic homes open for tours. Come early and stay late.

Costume-con 33 has made it possible for our members to get a great rate so you cannot just come for the convention but also enjoy a bit of a mini vacation here in Charleston. Hotel rates for CC 33 begin Weds May 13, 2015 and go to Tues May 19, 2015 so you can check in the Wednesday prior to the con and check out the Wednesdays after so you can spend a little extra time here in what Conde Nast

Traveler has once again voted Americas favorite vacation spot.

With the free shuttle bus service that leaves from the downtown visitors' center you can get to many attractions Charleston offers such as:

The South Carolina Aquarium: Home to more than ten thousand plants and animals including North American River Otters, loggerhead sea turtles, alligators, great blue herons, hawks, owls, lined seahorses, jellyfish, pufferfish, green moray eels, horseshoe crabs, sea stars, pythons, and sharks. The largest exhibit in the Aquarium is the Great Ocean Tank, which extends from the first to the third floor of the Aquarium; it holds more than 385,000 US gallons (1,460,000 l) of water and contains more than seven hundred animals. The Aquarium also features a Touch Tank, where patrons may touch horseshoe crabs, Atlantic stingrays, and other marine animals.

The Charleston Museum is the oldest museum in the United States founded in 1773 and opened to the public in 1824 Exhibits include: Charleston furniture, Charleston silver' Low country textiles, including costumes, quilts, and needlework South Carolina ceramics Egyptian artifacts, Nineteenth-century firearms and more.

Fort Sumter: The fort that is best known as the site upon which the shots that started the American Civil War were fired, on April 12, 1861 marking the beginning of the bloodiest war ever fought on American soil. Or you can rent a car and venture out to discover the “Low Country” around Charleston.

Patriots Point: A naval and maritime museum on Charleston Harbor with the center piece of the museum being the World War II aircraft carrier, the USS YORKTOWN. Patriots Point has become one of the state’s major tourist attractions with more than 270,000 visitors each year

Drayton Hall: An 18th-century plantation located on the Ashley River. An outstanding example of Palladian architecture in North America and the only plantation house on the Ashley River to survive intact through both the Revolutionary and Civil wars

Magnolia Plantation: Founded in 1676 by the Drayton family, has survived the centuries and witnessed the history of our nation unfold before it from the American Revolution through the Civil War and beyond. It is the oldest public tourist site in the Low Country, and the oldest public gardens in America.

Costume-Con 33 is also offering to its members 2 tours for those who cannot stay



Magnolia Plantation

the extra time but would still like to see Charleston with all its beauty.

The first tour will take place on Friday May 15th (day one of the con) at 9AM. Registered CC33 members will meet in the hotel lobby where you will board a GrayLine tour bus for the *City and Harbor Tour*. \$46.00 adults, \$31.00 Children (tour takes approx. 3 hours) this tour will cover 100+ historic points of interest along with an informative harbor cruise. (We are told that the bottlenose dolphin sightings are complementary.)

The second tour will take place on Monday at 11:00AM Registered CC33 members will meet in the hotel lobby where you will board a GrayLine tour bus for the “City and Plantation Tour”. \$64.00 adults \$37.00 Children (This tour will take most of the day) This tour will include the 100+ historic points of interest in the downtown area

then you will be whisked off to Historic Boone Hall Plantation, one of America’s oldest still working plantations. There you will be able to take a guided tour through the mansion as well as a self-guided tour through the original slave cabins and learn the history through storytellers.

Both of these tours will require a minimum of 12 adults and will require a \$25.00 deposit per person in advance so we may commit to these tours.

To sign up please send your deposit via check made payable to Costume-Con 33 (be sure to put either “City and Harbor tour or City and Plantation tour in the note line on your check)

Mail to: Costume-Con 33 Tours

C/o Con-Chair Sandy Swank

199 Cabrill Drive

Charleston, South Carolina 29414 Your balance can be paid when you pick up your con registration packet upon arrival. Signups and deposits must be received no later than April 30, 2015. If the minimum number of tour participants is not met, your deposit check will be returned with your con registration packet. Members will also find discount coupons in their welcome packages for other tours and attractions they may want to explore on their own.

Costume-Con 33 Workshop: *Electronics for Costumers*

By Lisa Ashton

We're planning a tutorial workshop, with hands-on "labs", in Electronics for Costumers. Somewhat like the session conducted by Sparkfun in Denver, we will cover the basics of how to reliably and safely light up a costume or prop.

For those who want to go beyond using existing electronics as-found, this workshop will teach the basics of connecting power source (batteries), one or more LEDs or lamps, the resistor(s) needed by the LEDs, possibly a switch, possibly a fuse (more important than you might think!), and of course wires, to make a working lighting circuit. The basics of voltage, current, and resistance will be shown step-by-step via a series of simple experiments. Series vs. parallel circuits, what a "short circuit" is and how to avoid them, battery choices, LED and lamp choices, wiring choices, and so on will all be part of the learning. Time permitting, we will show some examples of more complex electronics and show how to apply the principles of power sources, wiring, etc., to them.

Soldering will not be covered due to time and equipment requirements, but we'll present links to some terrific online videos on the subject.

We'll have a handout (or maybe a web site you can browse, print, etc., as you prefer)

that will provide reference data for all the details, along with additional information and suggestions for further learning.

Ringers are welcome! If you already know this stuff and want to help infect others with the joy of discovery, please do show up! You will not need a parts kit. Seating may be limited, but expect to be "mobile" anyway, so you can go to those who need a little help. And thank you!

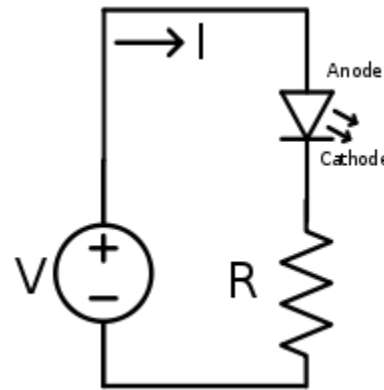

A simple LED circuit drawing.

Participation

You are of course free to just sit in... but to participate in the experiments, you must purchase, in advance, a \$30 parts kit (\$19 if you already own and can bring a multimeter; any other parts you already own can be substituted as well). Review the list, remove any items you already own and can bring, then click "order project" and "checkout". Small orders usually arrive from this company within a few days. They should be able to ship to you c/o the hotel, if

that is required to fit your travel schedule. These kits will not be available at the convention. Most of the parts can be used in later projects. Yes, the parts kit is missing resistors and LEDs! Those will be supplied by the instructor. No, the presenter does not get a percentage.

You should also bring six fresh AA batteries—they should not get used very much during the session, so you can use them for other things later.

If you can bring a pair of long- or needle-nose pliers (six inch overall length) and a small pair of diagonal cutters or other small-wire cutters, you will probably find them useful, but they are not required.

To order the parts kit, please go to the following website:

<http://www.mouser.com/ProjectManager/ProjectDetail.aspx?AccessID=7c6c5b601e>

At the time of this writing, the distributor shows the multimeter as "backordered". If this has not changed by the time you order, delete that item from your shopping cart and: 1) add item 685-MN35, a better multimeter for about \$9 more; or 2) go to Harbor Freight and buy their item 98025, which is the same meter originally called for but currently on sale for just \$6; or 3) bring a multimeter you already have or can borrow (any multimeter will do).

This Proxy Statement is for ICG members who will not be attending the Annual Meeting at Costume-Con. If you want to vote, print and complete the form and give it to someone who will be attending. You must sign this form for it to be valid.

=====

International Costumers' Guild 2015 Annual Meeting Proxy Assignment Form

On this _____ day of _____, 20____, I, _____, assign my vote to and authorize the below named member of the International Costumers' Guild, belonging to _____ Chapter, to represent me in all business coming before the 20____ Annual Meeting of the International Costumers' Guild.

Assignee Name*: _____

Address: _____

City: _____

State/Province: ZIP/Postal Code: _____

Assigner Name**: _____

Address: _____

City: _____

State/Province: ZIP/Postal Code: _____

Signature: _____

*Who you are authorizing to vote on your behalf.

**Your name.

About the ICG

Membership Benefits

ICG membership benefits include participation in local chapters, Special Interest Groups (SIGs), voting rights, eligibility for grants, online forums, learning and volunteer opportunities, and the newsletter, *International Costumer*.

ICG Online

Visit the ICG website for current information and resources:

<http://www.costume.org/>

Join us on Facebook:

<https://www.facebook.com/internationalcostumers>

Join the ICG-D Yahoo! group for lively discussions on costuming-related topics:

<http://groups.yahoo.com/group/icg-d>

Send comments and suggestions to the ICG board and standing committees:

Board of Directors

icg-board@costume.org

Budget and Finance Committee:

icg-financecommittee@costume.org

Costuming Arts & Sciences Grant Fund

icg-grants@costume.org

Public Relations Committee:

icg-prcommittee@costume.org

Publications Committee:

icg-pubscommittee@costume.org

Technology & Web Committee:

icg-techcommittee@costume.org

Editorial Board

Vicky Assarattanakul, Betsy Marks Delaney, Kathe Gust, Philip Gust, Bruce Mai, Patrick O'Connor, Jeanine Swick, Randall Whitlock.

Officers 2014-2015

President: Philip Gust

icg-president@costume.org

Vice President: Aurora Celeste

icg-vice-president@costume.org

Treasurer: Jeanine Swick

icg-treasurer@costume.org

Corresponding Secretary: Tonya Adolfson

icg-corr-secretary@costume.org

Recording Secretary: Kathe Gust

icg-rec-secretary@costume.org

Helpful Hands

International Costumer Editor: Vicky

Assarattanakul

icg-newsletter@costume.org

Webmaster: (*Position available*).

webmaster@costume.org

Acting webmaster: Philip Gust; Website

Assistants: Carole Parker, Susan Toker

Archivist: Pierre Pettinger

icg-archivist@costume.org

Gallery Admin: Nora Mai

gallery-admin@costume.org

GEL Administrator: Bruce MacDermott

gel-admin@costume.org

Assistant administrator: Elaine Sims

Parliamentarian: Pierre Pettinger

icg-parliamentarian@costume.org

The Kennedy Memorial Archives and Gallery

The ICG's Pat & Peggy Kennedy Memorial Archives is the world's largest archive of photographs, video and paper ephemera, spanning 70+ years of Science Fiction costuming. Exhibits include an online photo gallery (<http://www.costume.org/gallery2/>) and the ICGArchives YouTube channel (<http://www.youtube.com/user/ICGArchives>).

The International Costumer

The *International Costumer* newsletter is published bi-monthly by the ICG. The current issue is for members only. Back issues are freely available to the costuming community on the ICG website.

Online Submissions

We welcome short costuming articles, book reviews, event reports, and news items. Submit your copy as rtf, doc, docx or txt files to the International Costumer editor: icg-newsletter@costume.org. All graphics formats are accepted.

Contacting the Editor

Please contact the editor to report problems, or to offer comments and suggestions: icg-newsletter@costume.org.

Newsletter Delivery

The *International Costumer* is available as both an online and print edition. Your preference is part of your ICG membership record. To change or verify your preference, contact your local chapter.

If your postal or e-mail address changes, notify your local chapter promptly, or send your updated information to icg-membership-corrections@costume.org. Returned copies of the print edition cannot be re-mailed.

Members who have an e-mail address on record are notified when a new issue is available. Access the online edition at <http://www.costume.org/currentnewsletter>. The user name is "costumer" and the password is "CC33bound".